

CONTROL SIMBOLOGY



-  INSPECTION MEASURE
-  DRAWING REVISION
- 'C' = CUT 'D' = BEND

TABLA DE TOLERANCIAS ESTANDAR DE NO ESPECIFICARSE

TOLERANCES OF FINISHED PART		GENERAL TOLERANCES	
RANGO	TOLERANCIA	DIAMETROS	ANGULAR
0 mm - 999 mm	± 1 mm	NO ESPECIFICADO	± 2°
1000mm- 5m	± 2 mm		
5 m-12 m	± 3 mm	ESPECIFICADO	± 0.05
12m-100m	±10 mm		

MATERIAL	ITEM	WEIGHT (kg)	FINISH
N/A	N/A		CLEAN SURFACES WITHOUT BURRS

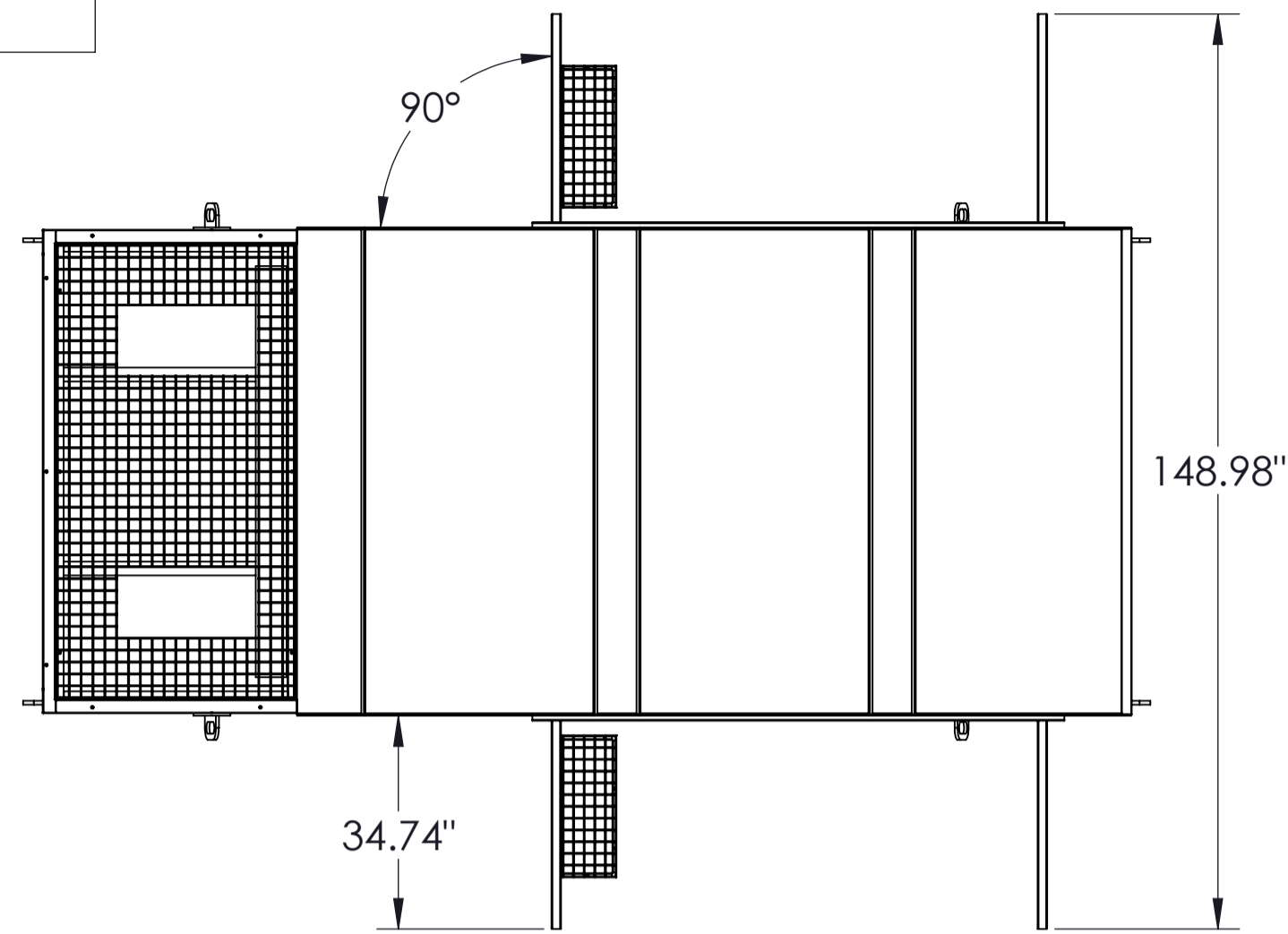

TOP VIEW

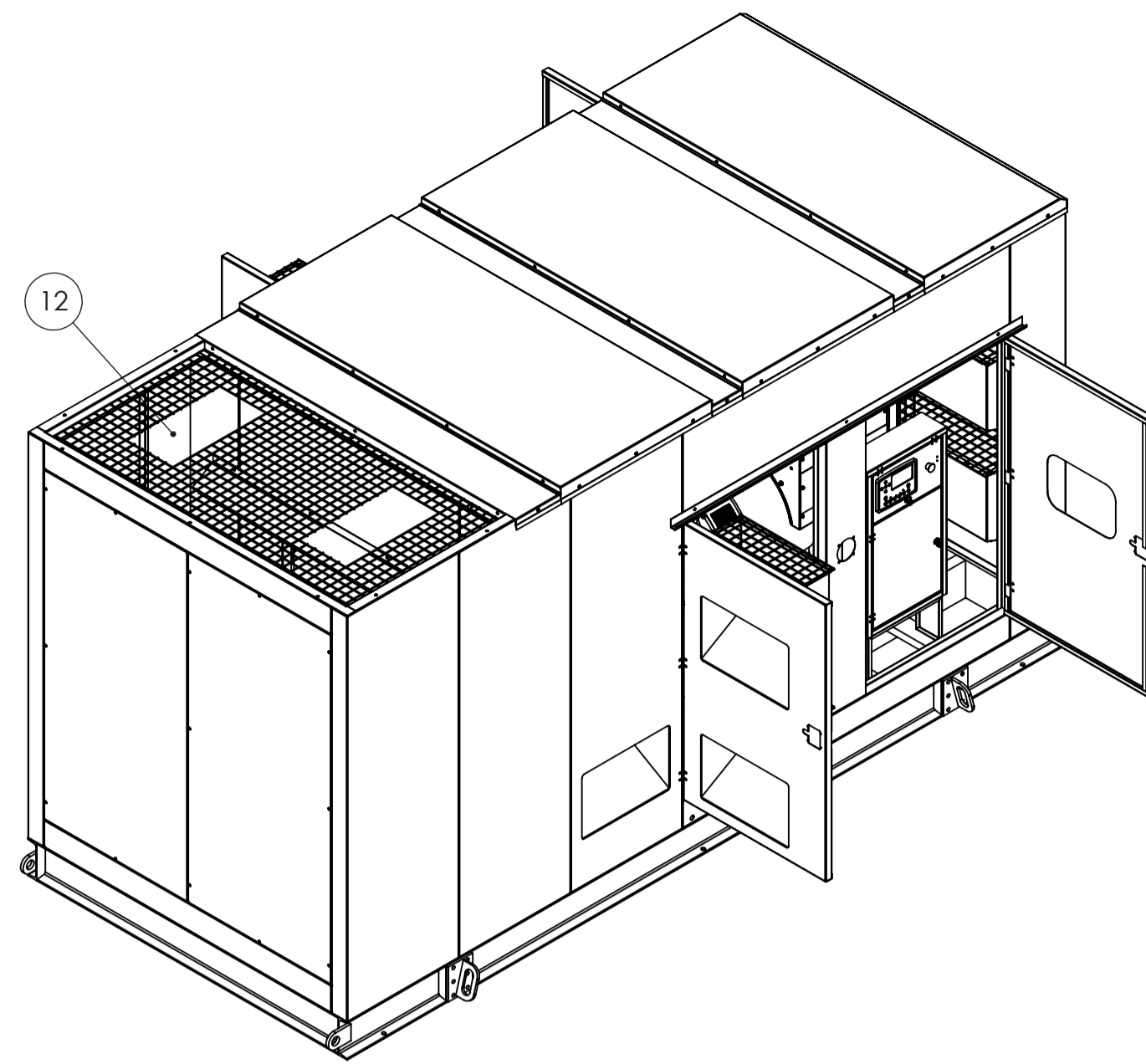

ISOMETRIC VIEW

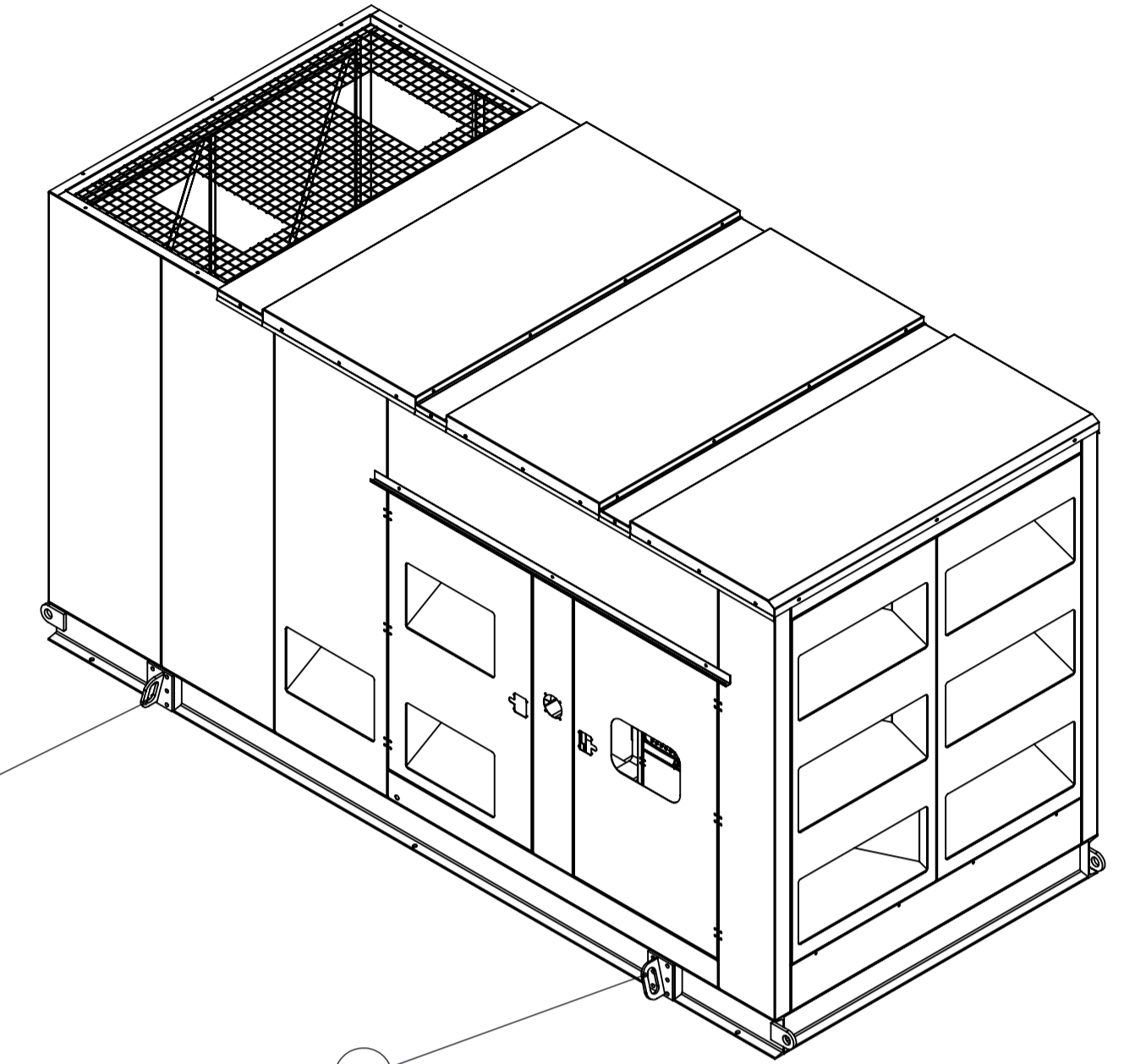

ISOMETRIC VIEW

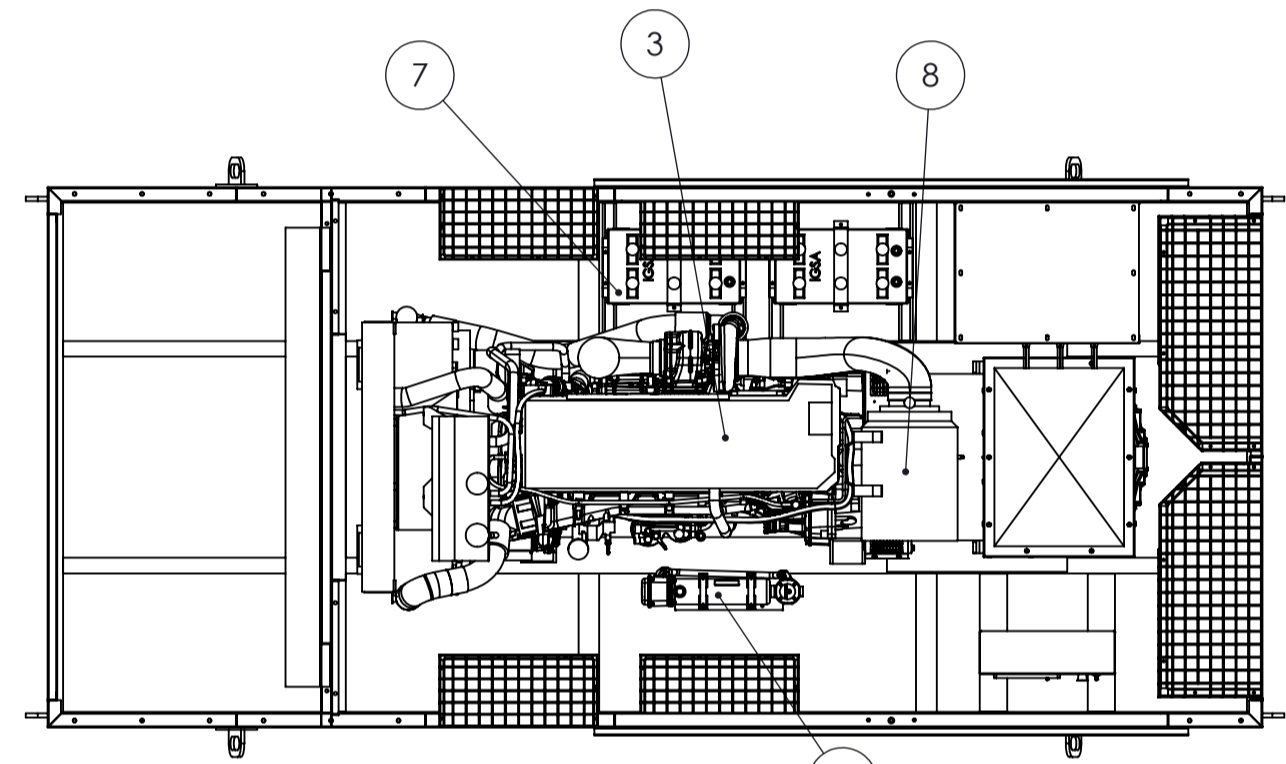

SECTION B-B

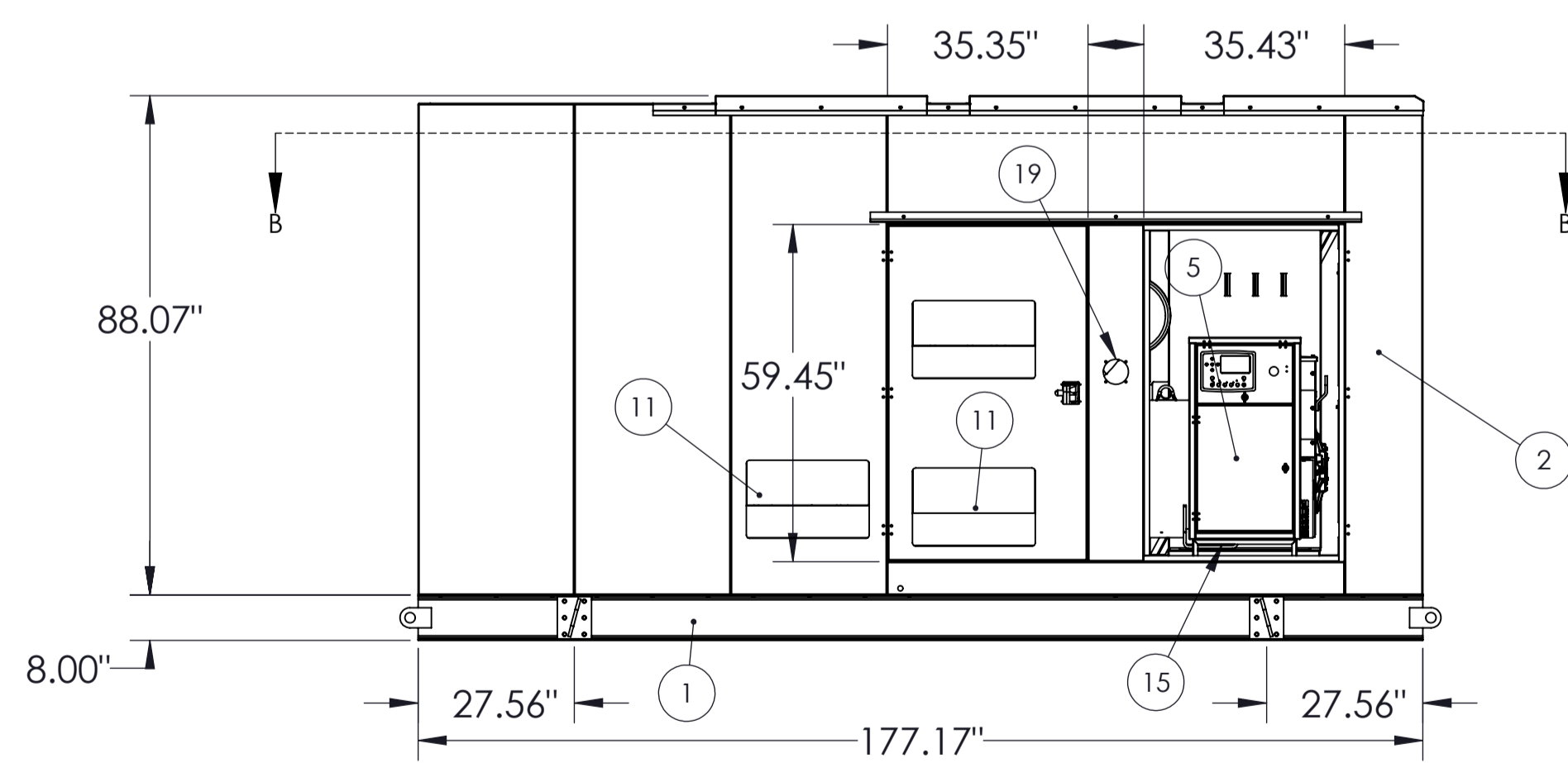

RIGHT VIEW

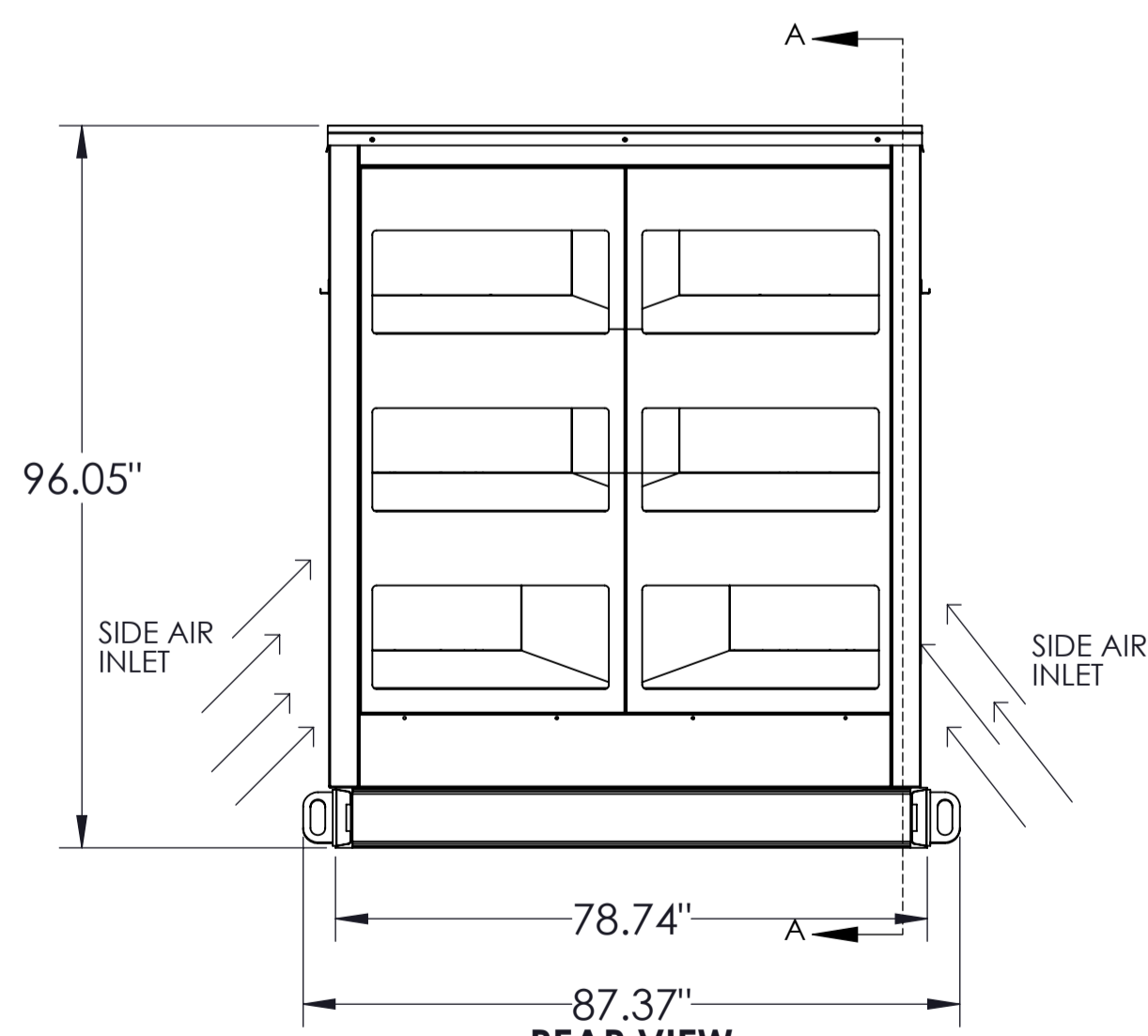

REAR VIEW

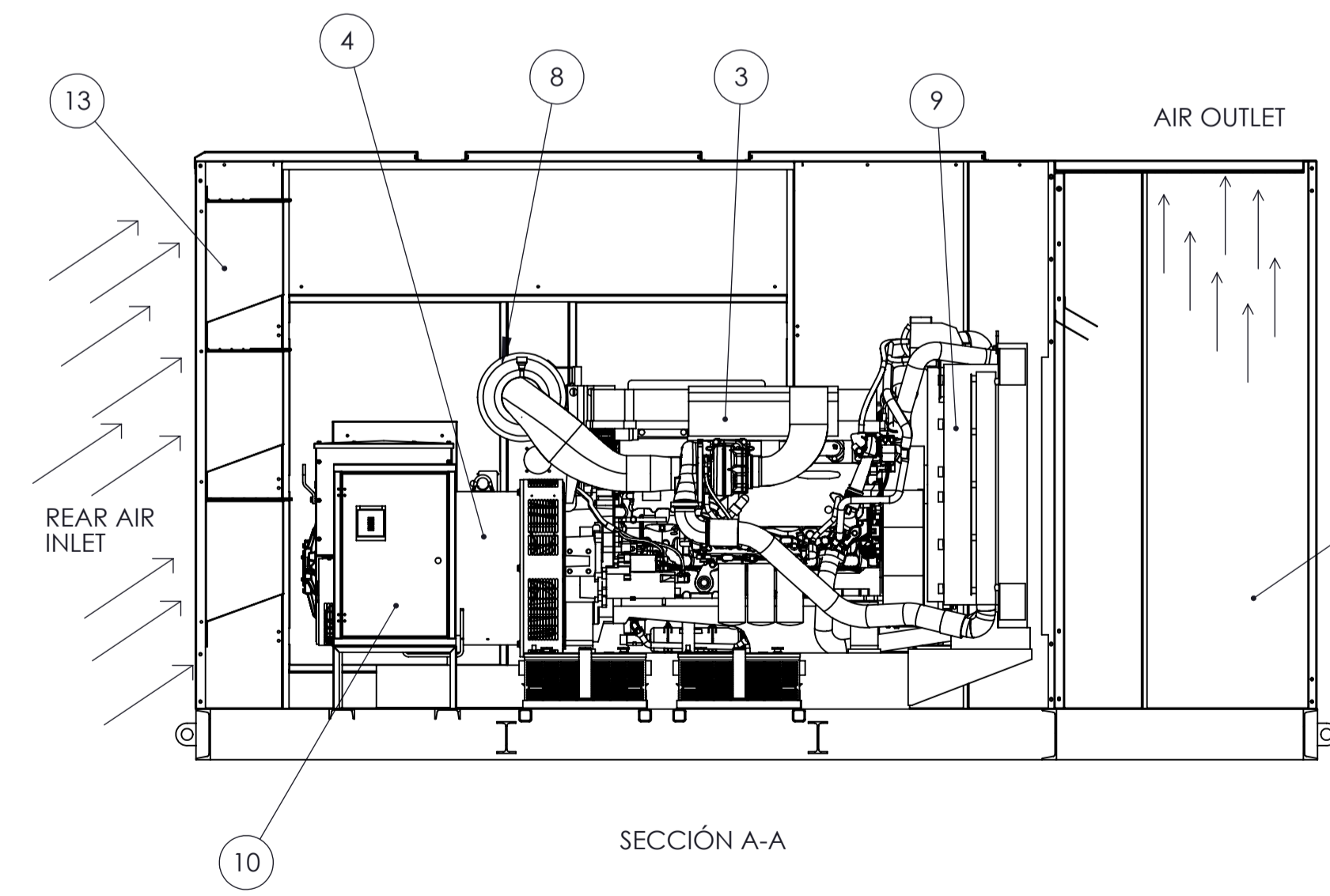

SECCIÓN A-A

ITEM NO.	DESCRIPTION
1	CHASSIS
2	MODULAR ACOUSTIC ENCLOSURE
3	ENGINE
4	ALTERNATOR
5	CONTROL PANEL
6	SILENCER
7	BATTERIES
8	AIR FILTER
9	RADIATOR
10	BREAKER
11	SIDE AIR INLET
12	FRONT AIR OUTPUT
13	REAR AIR INLET
14	LIFTING HOOK
15	OUTPUT CABLES
16	HEATER
17	COOLANT DRAINER
18	OIL DRAINER
19	EMERGENCY STOP

DEPTO.: ENGINEERING	DATE: 05/27/2019	DRAWN BY: ARG	REVIEWED BY: MBG	APPROVED BY: FJPR
ESCALA: N/A ACOT.: mm.	CUSTOMER: STD UL	DRAWING No: EG W/C VOLVO-STF 400kW 480 VAC 3PH		
PART NAME: BASE FRAME AND ENCLOSURE FOR ENGINE VOLVO-STAMFORD 400KW/480VAC 3PH/ABB BREAKER T5N 600A				REV.: 00
				SHEET 1 OF 2

IGSA S.A. DE C.V.
 HEAD QUARTERS: PASEO DE LA REFORMA No. 2977, COL. CUAJIMALPA, CP 05000, MEX. D.F.
 FACILITIES: HIGHWAY ANIMOLULCO-OCYOYACAC KM-5, LERMA EDO. DE MEXICO, CP 52740
 ENGINEERING DEPARTMENT: TEL.: 01 (55) 9626950 Ext.: 3018, 3020 & 3025.
 INFORMATION CONTAINED IN THIS DOCUMENT IS PROPEERTY OF IGSA COMPANY AND IT IS CLASSIFIED AS CONFIDENTIAL, HENCE IT CANNOT BE REPRODUCED TOTALLY OR PARTIALLY WITHOUT THE PREVIOUS AUTHORIZATION FROM IGSA S.A. DE C.V. MEXICO

CONTROL SIMBOLOGY

INSPECTION MEASURE

DRAWING REVISION

'C' = CUT 'D' = BEND

TABLA DE TOLERANCIAS ESTANDAR DE NO ESPECIFICARSE

TOLERANCES OF FINISHED PART		GENERAL TOLERANCES	
RANGO	TOLERANCIA	DIAMETROS	ANGULAR
0 mm - 999 mm	± 1 mm	NO ESPECIFICADO	± 2°
1000mm- 5m	± 2 mm		
5 m-12 m	± 3 mm	ESPECIFICADO	9.2-0.05
12m-100m	±10 mm		

MATERIAL	ITEM	WEIGHT (kg)	FINISH
N/A	N/A		CLEAN SURFACES WITHOUT BURRS

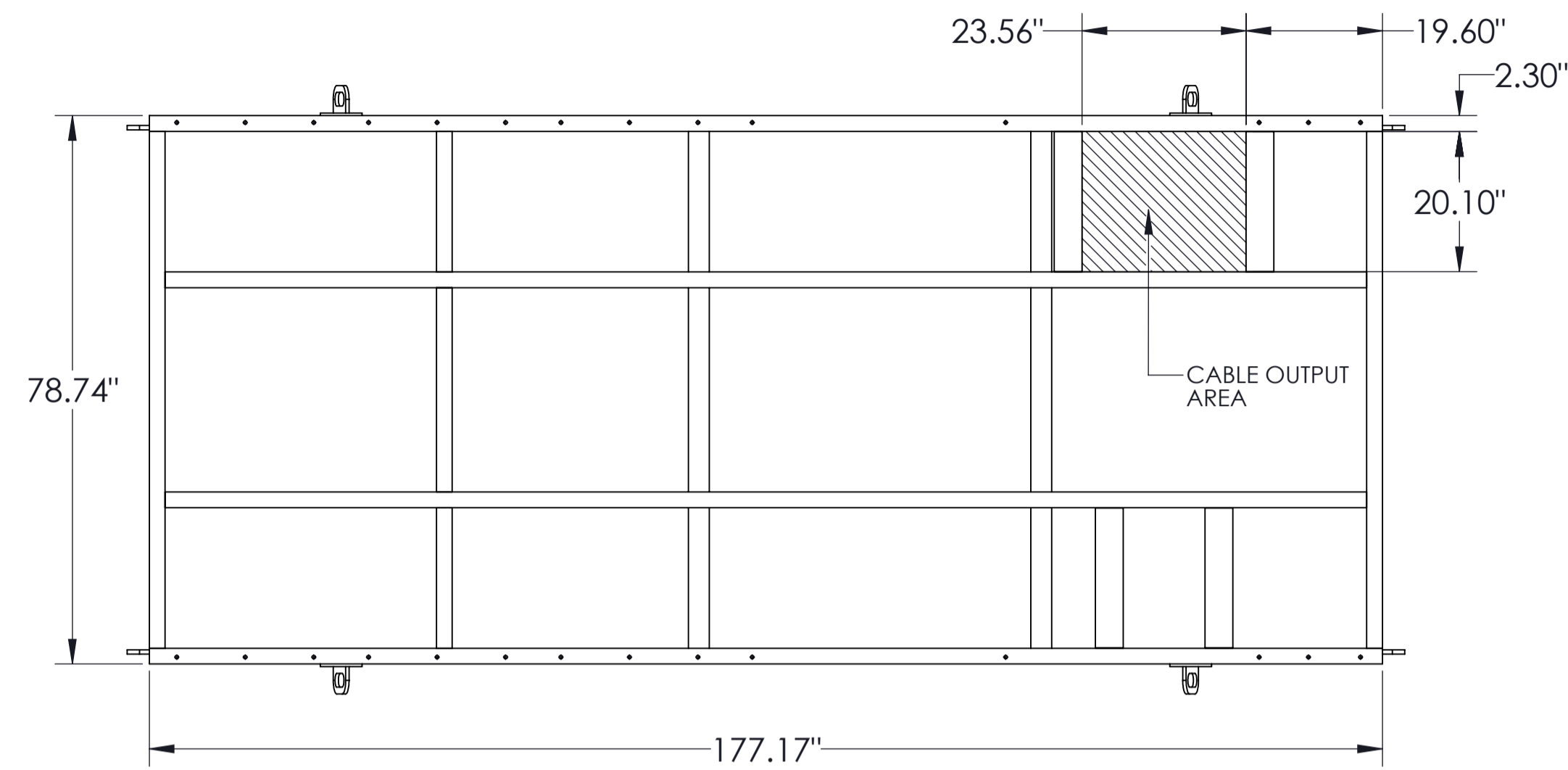

FRONT

REAR

CHASSIS TOP VIEW

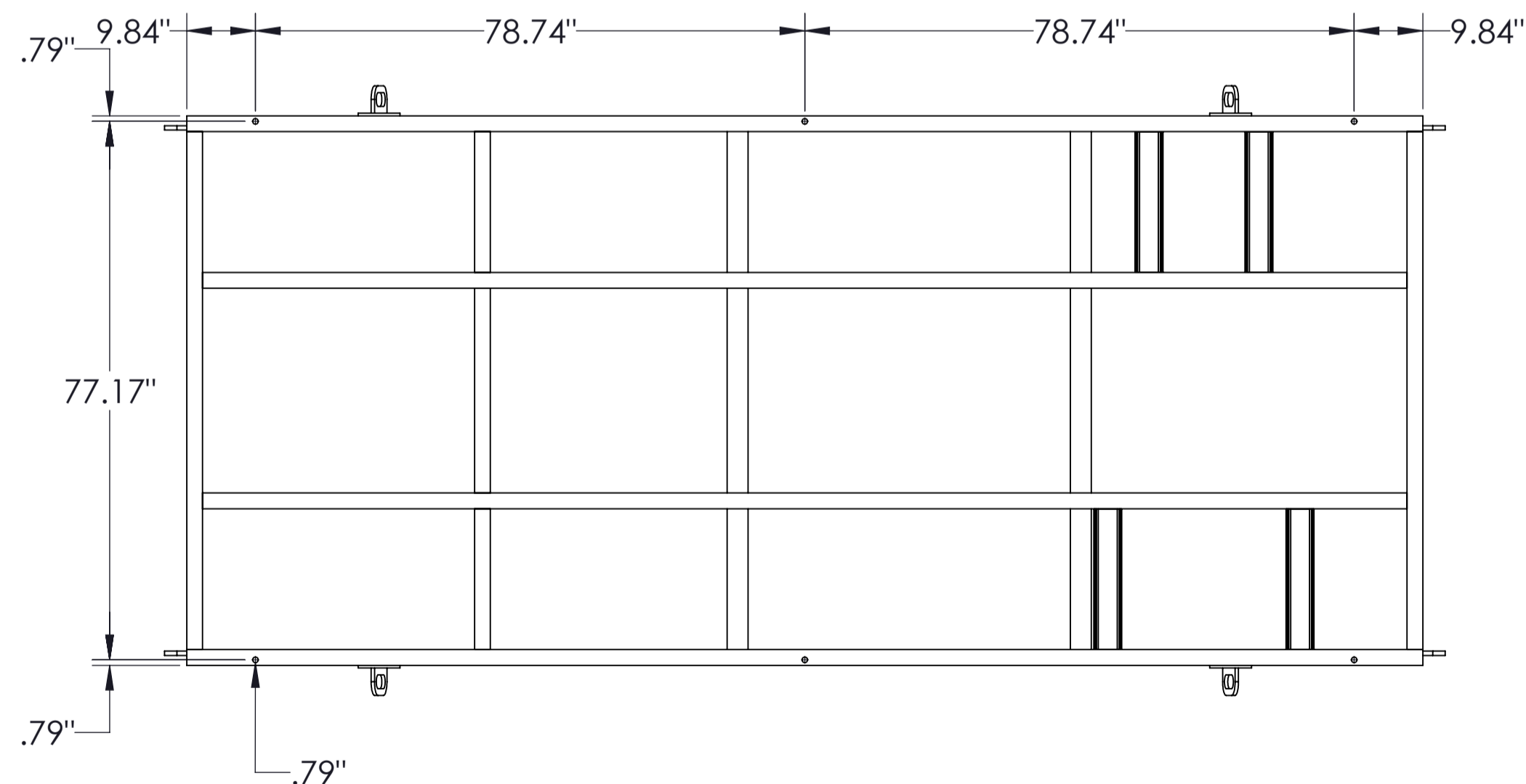
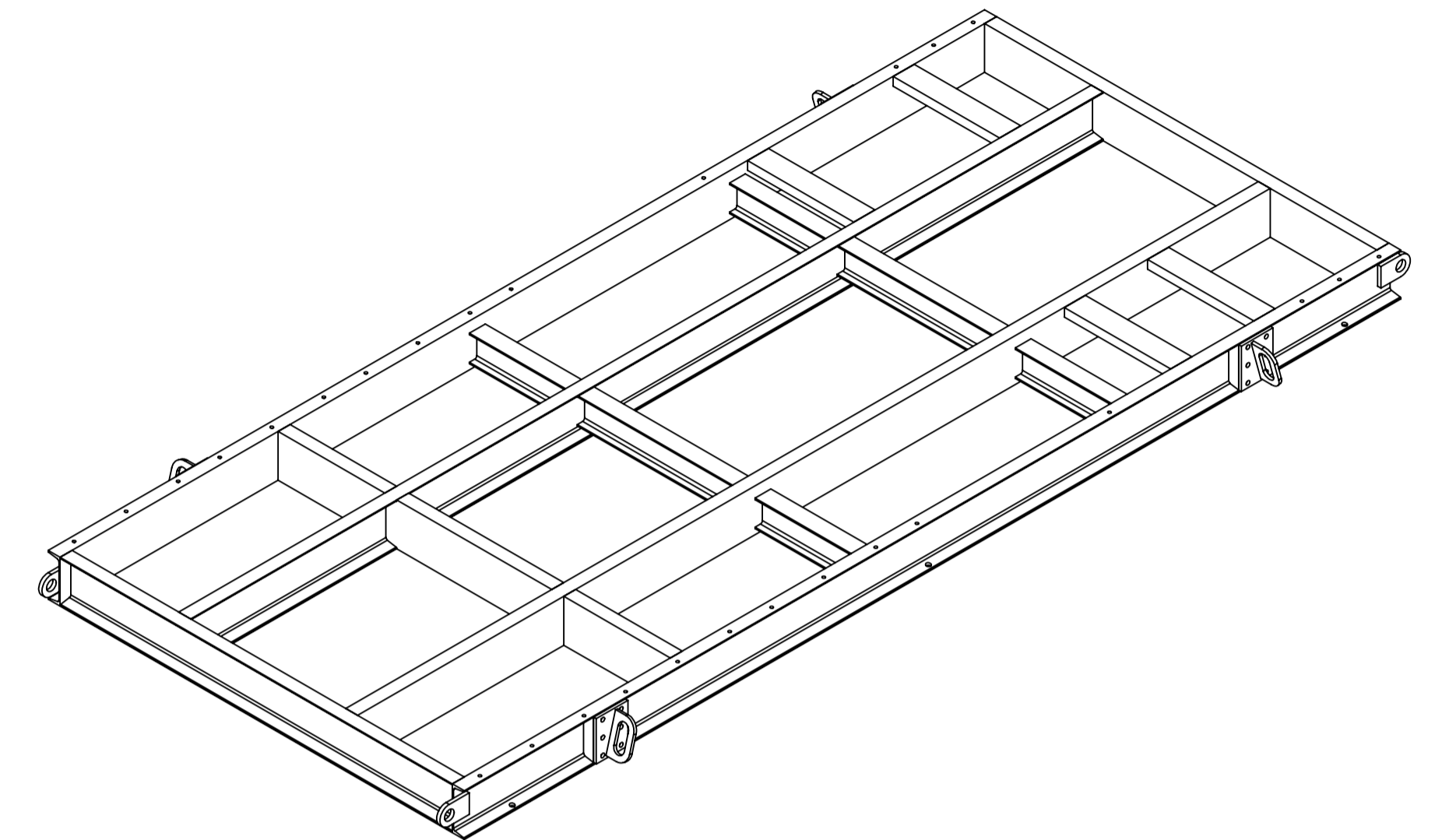

FRONT

REAR

**BOTTOM CHASSIS VIEW
ANCHORING TEMPLATE**

DEPTO.: ENGINEERING	DATE: 05/27/2019	DRAWN BY: ARG	REVIEWED BY: MBG	APPROVED BY: FJPR
ESCALE: N/A ACOT.: mm.	CUSTOMER: STD UL	DRAWING No: EG W/C VOLVO-STF 400kW 480 VAC 3PH		
PART NAME: BASE FRAME AND ENCLOSURE FOR ENGINE VOLVO-STAMFORD 400KW/480VAC 3PH/ABB BREAKER T5N 600A				REV.: 00
				SHEET 2 OF 2

IGSA S.A. DE C.V.
HEAD QUARTERS: PASEO DE LA REFORMA No. 2977, COL. CUAJIMALPA, CP 05000, MEX. D.F.
 FACILITIES: HIGHWAY ANOMOLULCO-OCYOYACAC KMS. LERMA EDO. DE MEXICO, CP 52740
 ENGINEERING DEPARTMENT: TEL.: 01 (55) 5626550 Ext.: 3018, 3020 & 3025.

INFORMATION CONTAINED IN THIS DOCUMENT IS PROPEPTY OF IGSA COMPANY AND IT IS CLASSIFIED AS CONFIDENTIAL, HENCE IT CANNOT BE REPRODUCED TOTALLY OR PARTIALLY WITHOUT THE PREVIOUS AUTHORIZATION FROM IGSA S.A. DE C.V. MEXICO